

MOTOR SPECIFICATION SHEET

MODEL : CNHM05-6090-35 (LT) (Motor model : SF-JRG 1/2HP 4P)

USED FOR : GEAR MOTOR

DESCRIPTION	DETAIL				
PHASE	3				
MODEL NAME	CNHM05-6090-35				
RATED OUTPUT, HP (kW)	1/2 (0.4)				
POLE	4				
CODE	MEATH CODE : 1G1035-005N60901				
OUTLINE DRAWING NO.	OMM74O380-A				
RATED VOLTAGE (V)	220	380	415	220	440
RATED FREQUENCY (Hz)	50	50	50	60	60
RATED CURRENT (A)	2.00	1.15	1.20	1.80	1.00
RATED SPEED (min ⁻¹) *	40	40	41	49	49
THERMAL CLASS	155(F)				
RATING	S1 (CONTINUOUS)				
ENCLOSURE CONSTRUCTION	TOTALLY ENCLOSED FAN COOLED				
DEGREES OF PROTECTION	IP55				
METHOD OF COOLING	IC411				
FRAME NO.	71M				
WEIGHT (kg)	15				
STANDARD	IEC 60034-1, JEC-2137-2000				
INSTALLATION	FOOT MOUNTED				
ROTATION	CCW (VIEWED FROM SHAFT END)				
BEARING	LOAD SIDE : 6203ZZ OPPOSITE SIDE : 6201ZZ				
BEARING GREASE	UREA GREASE				
CIRCUMSTANCE	AMBIENT TEMPERATURE : -20 ~ +40°C				
CONDITION	AMBIENT HUMIDITY : 95%RH OR LESS ABOVE SEA LEVEL : 1000m OR LESS ENVIRONMENT : NO BURSTING/EROSIVE GAS OR VAPOR				
COLOR	MUNSELL N5.5 (GRAY)				
TERMINAL BOX	NO. OF LEAD WIRES : 6 SOURCE CONNECTION : TERMINAL BLOCK				
INSULATION RESISTANCE	BY DC 500V MEGGER - ≥100MΩ				
DIELECTRIC TEST	AC 50Hz 1800V - 1min. (Based on rated voltage 380V)				
GEAR RATIO	1 : 35				
GEAR LUBRICANT	GREASE (Filled from factory.)				
SERVICE FACTOR	1.53				
MATERIAL	FRAME : STEEL PLATE BRACKET (GEAR SIDE) : CAST IRON BRACKET (OPP SIDE) : STEEL PLATE GEAR CASE : ALUMINIUM SHAFT (MOTOR) : STEEL SHAFT (GEAR OUTPUT) : STEEL STATOR CORE : ELECTRICAL STEEL WIRE : ENAMELLED COPPER MAGNET WIRE INSULATOR : POLYESTER FILM VARNISH : EPOXY DENATURALIZATION POLYESTER ROTOR CORE : ELECTRICAL STEEL CONDUCTOR : ALUMINIUM TERMINAL BOX : STEEL PLATE PAINTING : POLYURETHANE RESIN				
PRODUCTION COUNTRY	THAILAND				

* This value is calculated by MOTOR RATED SPEED / GEAR RATIO.

(Catalog value is specified by follow Gear maker specification, 50/60Hz = 41/50min⁻¹.)

Specifications subject to change without notice.

SPECIFICATION SHEET NO.				
SS-M-7372-A				

MODEL CNHM THREE PHASE INDUCTION MOTOR OUTLINE DRAWING

GEAR MOTOR
TOTALLY ENCLOSED FAN COOLED
DEGREES OF PROTECTION IP55
DUST & WATER JET PROOF

CUSTOMER _____
USER _____
FOR _____
CUSTOMER'S ORDER NO. _____
QUANTITY _____
MFG. ORDER NO. _____

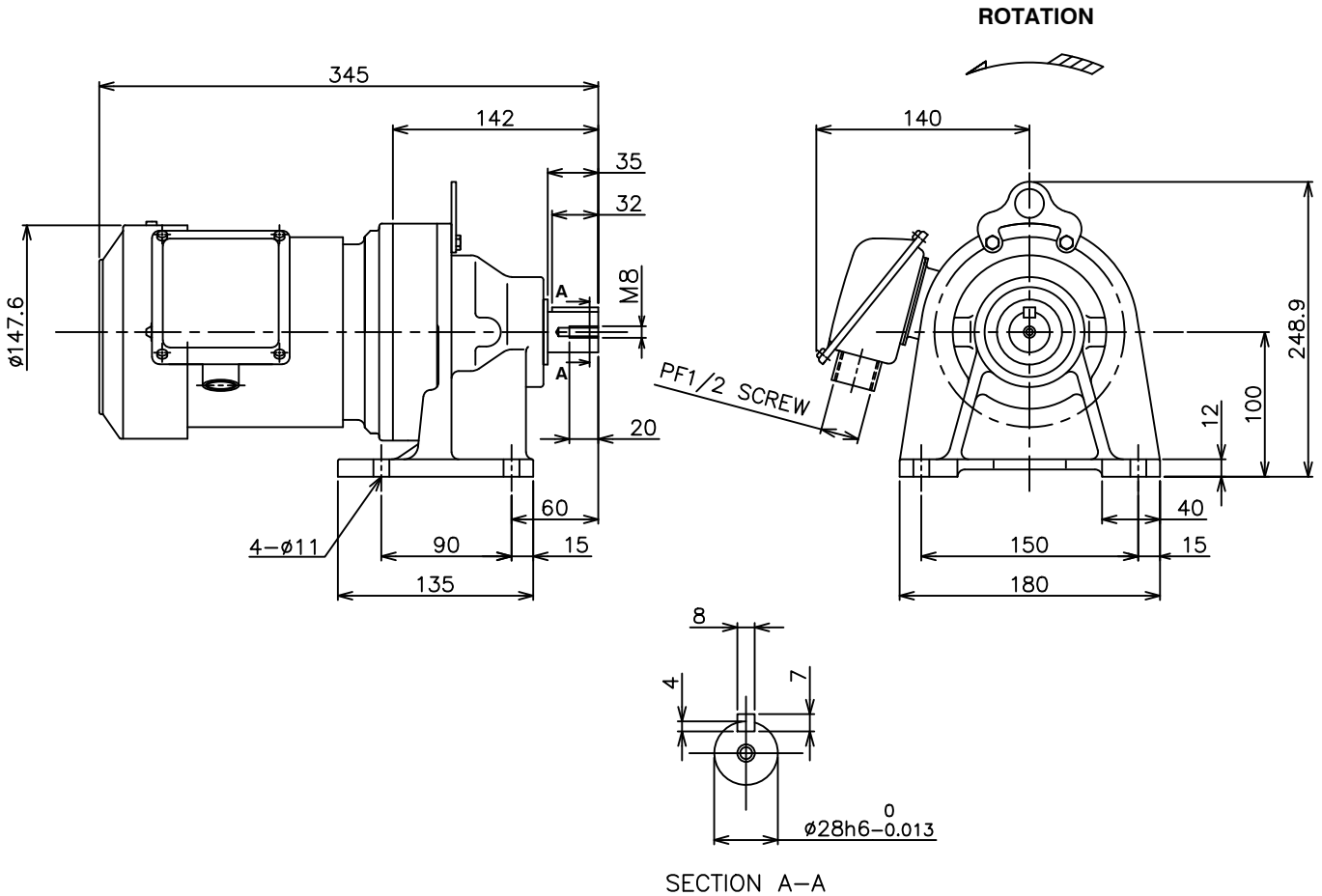

YOUR ORDER	MOTOR FRAME SIZE	RATING	TH. CLASS	AMB. TEMP	BEARINGS		COLOR	DIRECTION OF ROTATION	NO. OF LEAD WIRES	REMARKS
					LOAD SIDE	OPP. SIDE				
	71M	S1 (CONT.)	155(F)	40°C	6203ZZ	6201ZZ	GRAY (MUNSELL N5.5)	CCW	6	

YOUR ORDER	MODEL NAME	RATIO	SERVICE FACTOR	MOTOR OUTPUT		POLE	HERTZ	VOLT	OUTPUT SPEED (rpm)	LUBRICATION TYPE	WEIGHT (kg)
				HP	kW						
	CNHM05-6090-25	1:25	1.68	1/2	0.4	4	50 60	220/380/415 220/440	58 70	GREASE (1)	15
	CNHM05-6090-29	1:29	1.56	1/2	0.4	4	50 60	220/380/415 220/440	50 60		
	CNHM05-6090-35	1:35	1.53	1/2	0.4	4	50 60	220/380/415 220/440	41 50		
	CNHM05-6095-43	1:43	1.51	1/2	0.4	4	50 60	220/380/415 220/440	34 41		

NOTE : (1) Grease had been filled from manufacturer already.

MITSUBISHI ELECTRIC AUTOMATION (THAILAND) CO., LTD.

		OUTLINE DRAWING NO.	REV.
DIMENSION IN mm.		OMM740380	A
SCALE : NTS			